

# THE JOHN MARSHALL REVIEW OF INTELLECTUAL PROPERTY LAW

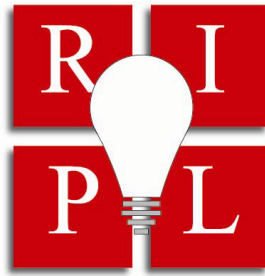

RECOGNITION AND PRESENTATION OF A “NEW RESULT” TO REACH A SAFE HARBOR

HAL MILTON

ABSTRACT

A safe harbor where a patent has the best chance of survival in a litigation storm is only established by dividing the preparation of a patent application into two separate categories: the recognition of the new result and the presentation of the new result throughout the patent application. The two famous cases of *Great Atlantic and Pacific Tea Co. v. Supermarket Equipment Corp.* and *Graham v. John Deere Co.* illustrate how the implementation of recognition and presentation might have prevented litigation or saved the patents.

Copyright © 2011 The John Marshall Law School



*Cite as Hal Milton, Recognition and Presentation of a “New Result” to Reach a Safe Harbor, 10 J. MARSHALL REV. INTELL. PROP. L. 583 (2011).*

RECOGNITION AND PRESENTATION OF A  
“NEW RESULT” TO REACH A SAFE HARBOR

HAL MILTON

I. OVERVIEW.....	585
II. INTRODUCTION.....	585
III. THE <i>KSR</i> BACK STORY.....	586
A. The '565 Teleflex Patent and the Prior Art.....	587
1. Rixon '183.....	587
2. Rixon '593.....	587
3. Teleflex/Engelgau '565 at Issue in <i>KSR</i> .....	588
B. The Prosecution Action that Led to <i>KSR</i> .....	588
C. Duty to Client: Absolute Novelty vs. Subjective Test.....	589
IV. RECOGNITION CATEGORY: THOMAS JEFFERSON'S BENEFIT TO SOCIETY.....	589
V. <i>A&amp;P</i> PROVES THE NECESSITY FOR A MORE STRUCTURED PRESENTATION CATEGORY.....	590
A. Separating the <i>A&amp;P</i> Patent from the Extrinsic Evidence.....	591
B. The <i>A&amp;P</i> Patent.....	591
C. The Opinion.....	592
D. The Lack of Presentation.....	594
E. Applying the Presentation Category to the <i>A&amp;P</i> Patent.....	595
1. Understanding the Enabling Embodiment.....	595
2. Analyzing, Pruning and Distilling to the Broad Claim.....	596
3. Dependent Claims.....	597
4. Detailed Picture Claim as Basis for Description.....	598
5. Drafting the Introductory Sections.....	598
6. The Field of Invention.....	599
7. The Prior Art.....	599
8. Summary of the Invention.....	600
9. Advantages of the Invention.....	601
F. The <i>A&amp;P</i> Opinion that Might Have Been.....	601
VI. <i>GRAHAM V. JOHN DEERE CO.</i> —ANOTHER FAILURE IN RECOGNITION AND PRESENTATION.....	602
A. Graham's Prior Art '811 Patent.....	603
B. The Graham '798 Patent in Issue.....	604
C. The Deficiencies in Recognition and Presentation.....	604
D. Advocacy vs. Presentation.....	605
E. The Preparation Steps Applied to the Graham '798 Patent.....	607
1. The Restructured Graham Patent Claims.....	607
2. The Graham Patent Description.....	608
3. The Graham Patent Introductory Sections.....	609
VII. THE PATENT PREPARATION STEPS DERIVED FROM THE CASES.....	610
A. Picture Claim.....	611

B. Broad Claim.....	611
C. Dependent Claims.....	611
D. Copying the Claims as a Core for the Description.....	611
E. Drafting the Introductory Sections.....	611
1. Drafting the Field of Invention.....	612
2. Drafting the Description of the Prior Art.....	612
3. Drafting the Summary of the Invention.....	612
4. Drafting the Advantages of the Invention.....	612
VIII. ADDITIONAL CASES VALIDATING THE PREPARATION STEPS.....	612
A. The Supreme Court has Recognized a Properly Presented New Result— <i>Webster Loom Co. v. Higgins</i> .....	613
B. An Entire Patent Focused on a New Result— <i>In re Adams</i> .....	614
C. Need for a Picture Claim— <i>Cannon Rubber v. The First Years</i> .....	615
D. Claims Limited by Introductory Sections: <i>Honeywell v. ITT</i> .....	616
E. Separating the New from the Old— <i>Multiform v. Medzam</i> .....	617
F. Successfully Incorporating the Preparation Steps— <i>Teleflex v. Ficosa</i> .....	620
IX. SUMMARY.....	622

# RECOGNITION AND PRESENTATION OF A “NEW RESULT” TO REACH A SAFE HARBOR

HAL MILTON\*

## I. OVERVIEW

A safe harbor where a patent has the best chance of survival in a litigation storm is only established by dividing the preparation of a patent application into two separate categories: the recognition of the new result and the presentation of the new result throughout the patent application. The two famous cases of *Great Atlantic and Pacific Tea Co. v. Supermarket Equipment Corp.*<sup>1</sup> (“A&P”) and *Graham v. John Deere Co.*<sup>2</sup> illustrate how the implementation of recognition and presentation might have prevented litigation or saved the patents.<sup>3</sup>

## II. INTRODUCTION

A landmark article on European patentability by Paul Cole should advance the preparation of patent applications for filing in the United States and in Europe.<sup>4</sup> Cole concludes that the United States and European cases show that “if our specifications fail to disclose results and advantages which support inventive character” we do so “at our peril.”<sup>5</sup> In referring to the United States, Cole states: “Although a bright-line rule has not been reasserted, enforcement of a patent where no new result can be identified or is disclosed in the patent must be considered to be

---

\* © Hal Milton 2011. Hal Milton teaches a course in patent application preparation at Wayne State University Law School. Hal currently manages the Dickinson Wright Intellectual Property Academy, training the art of patent application preparation (hmilton@dickinsonwright.com). He is the inventor of *patentarchitect.com*, a word processing program dedicated to preparing a patent application. U.S. Patent No. 7,890,851 (filed Mar. 19, 1999). He is in the final editing process of a book that is an extension of this article entitled *Preparing a Patent Application in Accordance with Appellate Opinions*. The opinions in this paper are solely of the author and are not necessarily the opinions of Dickinson Wright PLLC, its staff, or its clients.

<sup>1</sup> *Great Atl. & Pac. Tea Co. v. Supermkt. Equip. Corp.* (A&P), 340 U.S. 147 (1950).

<sup>2</sup> *Graham v. John Deere Co.*, 383 U.S. 1 (1966).

<sup>3</sup> *See, e.g., id.* at 23 (“Graham did not urge before the Patent Office the greater ‘flexing’ qualities of the ’798 patent arrangement which he so heavily relied on in the courts. The sole element in patent ’798 which petitioners argue before us is the interchanging of the shank and hinge plate and the consequences flowing from this arrangement.”); *A&P*, 340 U.S. at 149–50 (finding error when “the courts below perceived invention only in an extension of the counter” because: (1) “the extension is not mentioned in the claims” without a strained reading; (2) the extension was a “mere elongation of a merchant’s counter” and was not adequately disclosed; and (3) the extension as the improvement would invalidate the claims for including prior art unless the extension made up a new combination of elements).

<sup>4</sup> *See generally* Paul Cole, *KSR and Standards of Inventive Step: A European View*, 8 J. MARSHALL REV. INTELL. PROP. L. 14 (2008) (discussing the standards for obviousness or inventive step in the U.S. Patent and Trademark Office and the European Patent Office).

<sup>5</sup> *Id.* at 44.

very difficult.”<sup>6</sup> More affirmatively, Cole advises that evidence of a new result is necessary in a patent application under the European Patent Convention (“EPC”).<sup>7</sup>

Although no bright line exists in the United States, the cases evidence a requirement for a new result to support the exclusivity granted in a patent.<sup>8</sup> Certainly, the preparation of a patent application for filing under both the EPC and the United States Patent and Trademark Office (“PTO”) should include the new result requirement of the EPC. Fifty years of examining, drafting, and prosecuting patents, including the patent at issue in *KSR International Co. v. Teleflex, Inc.*,<sup>9</sup> coupled with the *KSR* opinion and the lessons therefrom, led the author herein to the objective standard of a new result. Inventors should be counseled that a new result should be sought out to justify the exclusive right of a patent.<sup>10</sup>

Cole alludes to two categories in the preparation of a patent application by the query: “What should be the consequences if either (a) the claimed combination of features provides no new result or (b) there is such a result but it is not disclosed in the written description?”<sup>11</sup> The recognition category is useful as an objective standard in counseling an inventor that a patent should not be pursued if there is no new result.<sup>12</sup> The study of litigated patents in this article provides specific steps for presentation of the new result in the various sections of the patent application to reach the safe harbor. Cole advises that the new result be set forth in the patent specification.<sup>13</sup> This article takes Cole’s appreciation of the presentation category further into a practical methodology by recounting the lack of a new result in the patent litigated in *KSR* and examining patents in other cases to suggest specifically to what extent and in which sections that new result is to be presented. The purpose of this methodology is to avoid the storms of litigation by establishing a safe harbor to obtain the grant and to sustain enforceability.

### III. THE *KSR* BACK STORY

Teleflex and *KSR* were competitors in the production of adjustable pedals for the automotive industry.<sup>14</sup> The basic concept of an adjustable pedal is to adjust the operating position of the brake pedal to accommodate different lengths of operator legs instead of adjusting the position of the seat.<sup>15</sup>

---

<sup>6</sup> *Id.* at 38.

<sup>7</sup> *Id.* at 39.

<sup>8</sup> See *Bilski v. Kappos*, 130 S. Ct. 3218, 3234 (2010).

<sup>9</sup> *KSR Int’l Co. v. Teleflex, Inc.*, 550 U.S. 398 (2007) (invalidating U.S. Patent No. 6,237,565 (filed Aug. 22, 2000)).

<sup>10</sup> Harold Milton & Patrick R. Anderson, *The KSR Standard of Patentability*, 89 J. PAT. & TRADEMARK OFF. SOC’Y 615, 630 (2007).

<sup>11</sup> See Cole, *supra* note 4, at 33.

<sup>12</sup> *Id.* at 34–35.

<sup>13</sup> *Id.* at 35.

<sup>14</sup> *KSR*, 550 U.S. at 410.

<sup>15</sup> *Id.* at 408.

### A. The '565 Teleflex Patent and the Prior Art

Although claim 4 of U.S. Patent 6,237,565 (“the '565 patent”) was invalidated in *KSR* by prior art that was not considered by the PTO, the most pertinent prior art resided in U.S. Patent No. 5,632,183 (“the '183 patent”) and U.S. Patent No. 5,819,593 (“the '593 patent”), both granted to Rixon and cited by Teleflex in the Background of the '565 patent. To avoid attacking the decision of the PTO to grant the Englegau '565 patent over Rixon’s prior patents, *KSR* found non-cited prior art.<sup>16</sup>

#### 1. Rixon '183

The '183 patent discloses a rod attached via a lever to a rotatable pivot with the pedal slidable along the rod.<sup>17</sup> A mechanical remote-control cable is connected to the lever for transmitting motion to the brake system in response to the brake-applying rotation of the pedal.<sup>18</sup>

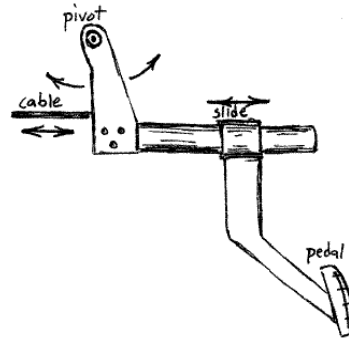

#### 2. Rixon '593

The '593 patent discloses a pedal attached to a rotatable pivot with the pivot slidable along a rod.<sup>19</sup> An electronic sensor is disposed at the pivot to transmit a signal to the brake system, *i.e.*, brake-by-wire instead of mechanical cable.<sup>20</sup>

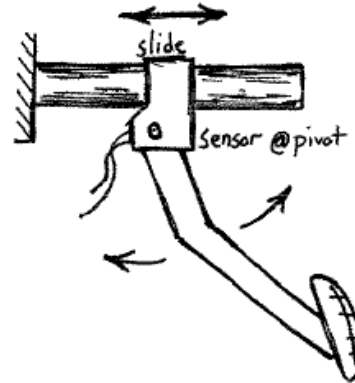

<sup>16</sup> *Id.* at 411–12.

<sup>17</sup> U.S. Patent No. 5,632,183 col. 3 ll.10–23 (filed Aug. 9, 1995).

<sup>18</sup> *Id.* at col. 3 ll.35–46.

<sup>19</sup> U.S. Patent No. 5,819,593 col. 3 l.10–col. 6 l.52 (filed Aug. 17, 1995).

<sup>20</sup> *Id.* at col. 4 ll.38–62.

### 3. Teleflex/Engelgau '565 at Issue in KSR

The '565 patent reverts to the structural relationship of the mechanical components in Rixon '183 where the rod is attached via a lever to a rotatable pivot with the pedal slidable along a rod.<sup>21</sup> The difference is that Engelgau '565 uses the electronic sensor taught by Rixon '593 in substitution for the mechanical cable connection in Rixon '183.<sup>22</sup>

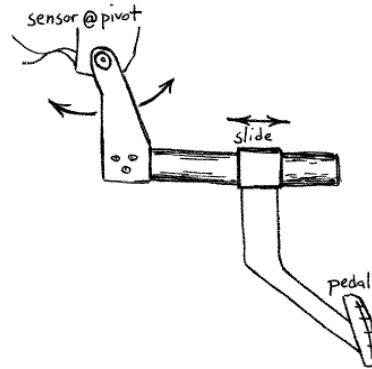

#### B. The Prosecution Action that Led to KSR

During a monthly patent meeting at Teleflex, marketing reported that KSR would produce an adjustable pedal assembly for a luxury production vehicle. The chief engineer requested a review of the patent portfolio to determine whether Teleflex owned a patent covering the KSR design. The KSR design pivotally connected the pedal to another lever arm which was in turn pivotally connected to the vehicle instead of the rectilinear sliding movement of the Rixon rod patents.

No Teleflex patent existed covering the KSR design, but the Engelgau patent application was pending and could support a claim covering the KSR design.<sup>23</sup> As filed, the Engelgau patent application focused on the electronic sensor being fixed on the vehicle whereby the pedal position is adjusted rectilinearly along the rod and the sensor detects only rotation of the rod relative to the vehicle support.<sup>24</sup> Claims 1–3 are limited to this combination and the application was focused on this specific rectilinear combination.<sup>25</sup> However, in order to cover the KSR design, claim 4 was submitted during prosecution to eliminate the rectilinear movement and merely claim a sensor to detect rotation of the pedal independently of pedal position adjustment, regardless of whether the adjusting movement was rectilinear or rotary.<sup>26</sup>

There was no new result flowing from the combination in claim 4 of the Teleflex patent; it was a combination of old elements from the prior art with each element performing for the reason selected without the combination producing a new result.<sup>27</sup>

<sup>21</sup> See U.S. Patent No. 6,237,565 col. 2 ll.27–44 (filed Aug. 22, 2000).

<sup>22</sup> Compare *id.* at col. 3 ll.14–39 (attaching an electronic throttle control to either a pivot member), with U.S. Patent No. 5,819,593 col. 3 ll.46–67, col. 5 ll.38–62 (placing an electronic sensor within the slidable housing) and U.S. Patent No. 5,632,183 col. 3 ll.35–46 (using a cable driven by the shaft of the pedal).

<sup>23</sup> See U.S. Patent No. 6,237,565 fig.1.

<sup>24</sup> *Id.* at col. 5 ll.31–38.

<sup>25</sup> *Id.* at col. 3 ll.39–52, col. 5 l.26–col. 6 l.16.

<sup>26</sup> See *id.* at col. 6 ll.17–36.

<sup>27</sup> *KSR Int'l Co. v. Teleflex, Inc.*, 550 U.S. 398, 422 (2007) (holding that a person having ordinary skill in the art could have combined the Asano patent with a pedal position sensor as in claim 4 and would have seen the benefits of doing so).

*C. Duty to Client: Absolute Novelty vs. Subjective Test*

It is very difficult to explain the subjective test of obviousness to a client when legislators and courts have not been able to provide a precise definition of such a subjective test. In response to an explanation of the subjective test of obviousness, the chief engineer instructed us to try to obtain claim 4 because, to him, the combination had absolute novelty. A client will accept the decision of the PTO that a claim is not patentable, but is often reluctant to accept the mere opinion of counsel that an invention is obvious, especially when counsel has an apparent record of obtaining patents on inventions of seemingly equal margins of novelty. In this case, claim 4 survived PTO examination but not the subsequent litigation.<sup>28</sup>

When discussing a potential invention with a client, the author now looks for and advises the client that the invention must provide a new result, something beneficial to society to justify a patent.

## IV. RECOGNITION CATEGORY: THOMAS JEFFERSON’S BENEFIT TO SOCIETY

Both Cole and this author rely on Thomas Jefferson for the standard of identifying a benefit to justify the exclusive right of a patent, *i.e.*, the standard of patentability.

Inventions then cannot, in nature, be a subject of property. Society may give an exclusive right to the *profits arising from them*, as an encouragement to men to pursue *ideas which may produce utility*, but this may or may not be done, according to the will and convenience of the society, without claim or complaint from anybody.<sup>29</sup>

The courts are more likely to positively evaluate a patent for “ideas which may produce utility” and “profits arising from them,” as suggested in Jefferson’s quote above. The U.S. Supreme Court reemphasized Jefferson’s policy in *Graham v. John Deere Co.* by stating:

The grant of an exclusive right to an invention was the creation of society—at odds with the inherent free nature of disclosed ideas—and was not to be freely given. Only inventions and discoveries which furthered human knowledge, and were new and useful, justified the special inducement of a limited private monopoly.<sup>30</sup>

In determining whether to proceed with a patent application on a new product, most invention owners need a positive or negative evaluation of patentability. An objective test is needed in order to have a meeting of the minds with such an invention owner as to patentable subject matter. The article *The KSR Standard of*

---

<sup>28</sup> *KSR*, 550 U.S. at 427–28.

<sup>29</sup> Letter from Thomas Jefferson to Isaac McPherson (Aug. 18, 1813), *in* 13 THE WRITINGS OF THOMAS JEFFERSON 334 (Andrew A. Lipscomb & Albert Ellery Bergh eds., 1903) (emphasis added).

<sup>30</sup> *Id.* at 9.



*Patentability*<sup>31</sup> concludes that the standard has not changed since the Supreme Court decision of *Hotchkiss v. Greenwood*<sup>32</sup> in 1850 and states that “the mere selection of elements from various prior art references . . . [combined] together with no new function or unpredictable result is an obvious use of common sense by one skilled in the art, and, therefore, not patentable.”<sup>33</sup> This coincides with Cole’s observation that a patent application should be based upon a new result.<sup>34</sup> The reconciliation of the guidelines in the *The KSR Standard of Patentability* article with Cole’s new result requirement establishes a framework under which patent applications can be prepared within a safe harbor of patentability, i.e., a new result. The objective guidelines are as follows:

- **No New Result:** A naked aggregation, catalog or combination of old elements from the prior art with no new result will not be enough to justify the exclusive right of a patent.<sup>35</sup>
- **New Result:** A new result from a combination of elements, all independently old or at least one new element justifies the exclusive right of a patent and will be deemed a non-obvious inventive step.<sup>36</sup>
- **Presentation of New Result Facts:** The introductory sections of the patent application should focus on facts proving the new result resulting from the combination of elements recited in the broadest claim. Conversely, the new result and supporting facts should not be withheld from the application for submission during prosecution or litigation where they will likely be regarded as advocacy instead of fact.<sup>37</sup>

#### V. A&P PROVES THE NECESSITY FOR A MORE STRUCTURED PRESENTATION CATEGORY

The recognition category involves the objective new result standard of patentability that can be used to communicate with an invention owner to determine whether a patent application should be filed. The presentation category involves the specific recitation of that new result in various sections of the patent specification. Cole is correct that A&P met the recognition category in the extrinsic evidence by possessing a new result or function,<sup>38</sup> but he did not sufficiently detail and apply his “not disclosed in the written description” test to show that the A&P patent was wholly deficient in the presentation category.<sup>39</sup>

---

<sup>31</sup> Milton & Anderson, *supra* note 10.

<sup>32</sup> *Hotchkiss v. Greenwood*, 52 U.S. 248 (1850).

<sup>33</sup> Milton & Anderson, *supra* note 10, at 20 (emphasis omitted).

<sup>34</sup> See Cole, *supra* note 4, at 45–46.

<sup>35</sup> See *id.*

<sup>36</sup> *Id.*

<sup>37</sup> See *id.* at 38.

<sup>38</sup> See Paul Cole, *Supermarket Check-Outs Revisited*, PATENT WORLD, Mar. 1998, at 12.

<sup>39</sup> See *id.* (lacking any application of the test to A&P).

All of the arguments supporting a new result submitted outside the patent specification in obtaining and enforcing the patent can be disregarded as “the afterthought of an astute patent trial lawyer.”<sup>40</sup> It is rational to view the opinion of the Supreme Court in *A&P* as having disregarded the extrinsic evidence outside the patent specification and having merely relied upon the intrinsic presentation in the patent specification. This rationale requiring a presentation category in the patent specification reconciles Cole’s requirement for a “new result” and the decision in *A&P*.

#### A. Separating the A&P Patent from the Extrinsic Evidence

To close the gap between the existence of a new result and the lack of presentation of that new result in the patent application, the *A&P* patent is rewritten in a series of preparation steps herein that might have saved the *A&P* patent from its inherent or intrinsic demise.

#### B. The A&P Patent

The patent in question in the *A&P* case was U.S. Patent No. 2,242,408 (“the ’408 patent”),<sup>41</sup> issued to E.D. Turnham in 1938.<sup>42</sup> The invention was an open, three-sided, U-shaped frame or rack (20) on an elongated counter (15) at a cashier’s checkout

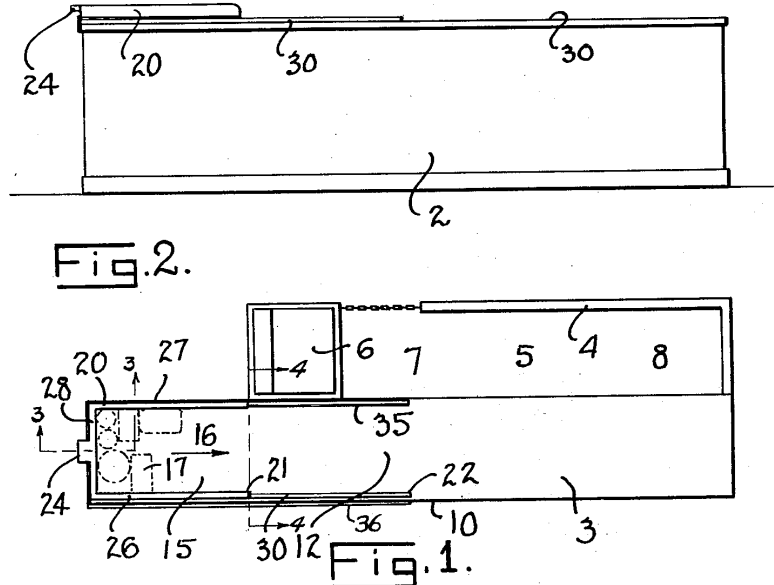

<sup>40</sup> See, e.g., *United States v. Adams*, 383 U.S. 39, 49 (1966) (stating that the express “object of disclosing a water-activated cell” as well as a “lack of reference to any electrolyte” until a few narrow, dependent claims showed “that respondents’ present reliance upon this feature was not the afterthought of an astute patent trial lawyer”).

<sup>41</sup> U.S. Patent No. 2,242,408 (filed Oct. 28, 1938).

<sup>42</sup> *A&P*, 340 U.S. at 148 n.1; U.S. Patent No. 2,242,408.

stand (7) used to pull grocery merchandise (17) from a waiting customer to the cashier.<sup>43</sup> The U-shaped frame (20) is unloaded when it is pushed back to its original position for the next customer to fill while leaving the grocery merchandise being checked out in front of the cashier.<sup>44</sup>

The cashier counter (2) presents a counter top (3) for receiving articles (17) of merchandise from a customer.<sup>45</sup> A recording cash register (6) is disposed adjacent the cashier counter (2) for operation by a cashier standing in the checkout stand (7) to record the articles (17) of merchandise for each customer.<sup>46</sup> An extension (15) of the counter and the counter top (3) receives articles (17) of merchandise for the next customer as the cashier records the articles (17) of merchandise for the previous customer.<sup>47</sup> The frame (20) is disposed on the counter top (3) for sliding movement between a receiving position (16) over the extension (15) and a checkout position (12) on the cashier counter (2) adjacent the cashier.<sup>48</sup> The frame (20) has a U-shape including a front side bar (26) and a rear side bar (27) joined by an end bar (28).<sup>49</sup> The frame (20) is open toward the recording cash register (6) to engage and move articles (17) on the counter top (3) from the receiving position (16) to the check out position (12).<sup>50</sup> The frame (20) then slides back to the receiving position (16) for receiving articles (17) of merchandise for another customer.<sup>51</sup> A stop (29), not shown in Figures 1 or 2, extends upward from the extension (15) for engaging the end bar (28) to limit sliding movement of the frame (20) off of the counter top (3) in the receiving position (16).<sup>52</sup> Channel members (30) interconnect the side bars (26, 27) and the counter top (3) for guiding the sliding movement of the frame (20) between the receiving and checkout positions (16, 12).<sup>53</sup> A handle (24) extends from the frame (20) for manually moving the frame (20) between the positions (16, 12).<sup>54</sup>

### C. *The Opinion*

The prior art relied upon was a closed, three-sided billiard-ball frame or rack.<sup>55</sup> The lower court upheld the patent by finding that triangular billiard-ball frames “are closed and are not self-unloading, as in the U-shaped rack.”<sup>56</sup> On appeal, the Supreme Court reversed the trial court and found that a three-sided rack was found

---

<sup>43</sup> U.S. Patent No. 2,242,408 col. 2 l.21–col. 3 l.45.

<sup>44</sup> *Id.* at col. 4 ll.1–12.

<sup>45</sup> *Id.* at col. 2 ll.21–26, col. 4 ll.5–10.

<sup>46</sup> *Id.* at col. 2 ll.26–41.

<sup>47</sup> *Id.* at col. 4 ll.1–5.

<sup>48</sup> *Id.* at col. 3 ll.26–35.

<sup>49</sup> *Id.* at col. 3 ll.36–39.

<sup>50</sup> *Id.* at col. 3 ll.39–45.

<sup>51</sup> *Id.* at col. 4 ll.5–12.

<sup>52</sup> *Id.* at col. 3 ll.46–53.

<sup>53</sup> *Id.* at col. 3 ll.54–75.

<sup>54</sup> *Id.* at col. 3 ll.31–35.

<sup>55</sup> *A&P*, 340 U.S. at 152–53 (using the lower court’s finding to hold that the combination did not change the functions of the elements and therefore “withdraws what already is known into the field of its monopoly and diminishes the resources available to skillful men”).

<sup>56</sup> *Great Atl. & Pac. Tea Co. v. Supermkt. Equip. Corp.*, 179 F.2d 636, 639 (6th Cir. 1950), *rev’d*, 340 U.S. 147 (1950).

in the prior art billiard-ball frame or rack.<sup>57</sup> The Supreme Court effectively found that three sides that form a frame to move articles over a surface was old and well known.<sup>58</sup>

The open U-shaped frame in *A&P* involved a significant new result in the cashier’s checkout stand that could not be attained by a closed, triangular, billiard-ball frame.<sup>59</sup> However, it appears that the Supreme Court applied the No-New-Result” guideline because of the presentation in the patent specification.<sup>60</sup> The Court noted: “Neither court below has made any finding that old elements which made up this device perform any additional or different function in the combination than they perform out of it.”<sup>61</sup> The Supreme Court held that the combination was obvious, and therefore not patentable, because a “patent for a combination which only unites old elements with no change in their respective functions . . . obviously withdraws what already is known into the field of its monopoly and diminishes the resources available to skillful men.”<sup>62</sup> The Court, in effect, applied the No-New-Result guideline to the patent document that is also applied in both *Hotchkiss*<sup>63</sup> and *KSR*.<sup>64</sup>

The *A&P* patent only once mentions the frame (20) as being U-shaped and buries the “frame being open” in claim 6.<sup>65</sup> Although a new result clearly existed when including the extrinsic evidence presented at trial,<sup>66</sup> the new result was not focused upon in the claims, or in the introductory sections of the patent.<sup>67</sup> The Supreme Court merely read the intrinsic patent and held the patent owner to the words of the patent specification, the words being also descriptive of the closed, triangular billiard-ball frame.<sup>68</sup>

The open, U-shaped frame was hugely successful at reducing the time customers spent at the checkout line, and it was widely accepted and adopted.<sup>69</sup> However, this advantage was buried in the last paragraph of the description of the ’408 patent.<sup>70</sup> The lower court found that the invention “handled 30% more customers, taken in 30% more money than formerly, and thus generally improved their efficiency.”<sup>71</sup>

---

<sup>57</sup> See *A&P*, 340 U.S. at 149 (stating that “the courts below perceived invention only in an extension of the counter”, “to receive a bottomless self-unloading tray”) (internal quotations omitted).

<sup>58</sup> *Id.* at 152.

<sup>59</sup> Compare U.S. Patent No. 2,242,408 col. 3 l.54–col. 4 l.14 (anchoring the frame to the top of the counter), with U.S. Patent No. 1,299,471 (filed Jul. 19, 1917) (showing a closed frame where the frame must be lifted to release the contents).

<sup>60</sup> See *A&P*, 340 U.S. at 152 (“Two and two have been added together, and still they make only four.”).

<sup>61</sup> *Id.*

<sup>62</sup> *Id.* at 152–53.

<sup>63</sup> See *Hotchkiss v. Greenwood*, 52 U.S. 248, 262 (1850).

<sup>64</sup> See *KSR Int’l Co. v. Teleflex, Inc.*, 550 U.S. 398, 418–19, 422 (2007).

<sup>65</sup> See U.S. Patent No. 2,242,408 col. 3 ll.36–39, col. 6 l.2 (filed Oct. 28, 1938).

<sup>66</sup> *A&P*, 340 U.S. at 149.

<sup>67</sup> See U.S. Patent No. 2,242,408.

<sup>68</sup> See *A&P*, 340 U.S. at 148–54 (mentioning the open frame only when the claim is recited).

<sup>69</sup> U.S. Patent No. 2,242,408 col. 4 ll.27–33.

<sup>70</sup> See *id.*

<sup>71</sup> *Great Atl. & Pac. Tea Co. v. Supermkt. Equip. Corp.*, 179 F.2d 636, 637 (6th Cir. 1950), *rev’d*, 340 U.S. 147 (1950).

These are extrinsic facts supporting and proving a new result.<sup>72</sup> An open frame clearly operates differently than a closed, triangular frame. Billiard balls are packed into the triangular frame for tight-knit placement on a spot on a pool table.<sup>73</sup> The U-shaped frame in *A&P* scoops in and drags randomly placed groceries along a counter for one-by-one removal by a cashier.<sup>74</sup> Nonetheless, the Supreme Court opinion delivered by Justice Jackson expressly disavowed any review of the facts by stating, “We set aside no finding of fact” and the “defect . . . [in the judgment was the] standard of invention.”<sup>75</sup>

#### *D. The Lack of Presentation*

The defect was not in the law, but in the facts as presented in the patent specification. The defect was not in the existence of a new result justifying a patent, but in the presentation of that new result throughout the sections of the patent. The '408 patent was not drafted to avoid a fact finding that the patent merely claimed a prior art three-sided frame.<sup>76</sup> The patent did not specifically nor precisely present the necessary open U-shaped frame which provided new results not attainable in the closed, triangular frame.<sup>77</sup>

Courts frequently read and rely upon the entire patent, like a contract, appearing to rely as much upon the facts set forth in the specification as upon the claims of a patent.<sup>78</sup> Often the courts will rely only on the intrinsic patent specification to the exclusion of extrinsic facts presented in advocacy.<sup>79</sup>

The '408 patent does not adequately claim a combination to produce a new result. All claims, except claim 6, were met by merely placing the closed, triangular billiard-ball frame on a “portion” of a grocery checkout counter.<sup>80</sup> The claims of the '408 patent recite the equivalent of a bottomless frame on said portion and within which the merchandise is deposited and arranged, and only claim 6 recites “said frame being open at the end adjacent the cashier’s stand.”<sup>81</sup> In addition, the introduction of the '408 patent broadly recites that an “object of the invention is to provide a frame whereby the goods of a customer may be grouped together and moved along the counter as a unit.”<sup>82</sup> This is a result that can be achieved by the prior art billiard-ball frame. Accordingly, the patent specification can easily be

---

<sup>72</sup> *Id.* at 638 (“The device satisfied an old and recognized want, and hence ‘invention is to be inferred, rather than the exercise of mechanical skill.’”).

<sup>73</sup> See U.S. Patent No. 1,299,471 col. 1 ll.13–30 (filed Jul. 19, 1917).

<sup>74</sup> See U.S. Patent No. 2,242,408 col. 4 ll.1–26.

<sup>75</sup> *A&P*, 340 U.S. at 153–54.

<sup>76</sup> See U.S. Patent No. 2,242,408 col. 4 l.34–col. 6 l.6 (failing to mention an open frame until the final claim).

<sup>77</sup> *Id.*

<sup>78</sup> *E.g.*, *Philips v. AWH Corp.*, 415 F.3d 1303, 1315 (Fed. Cir. 2005).

<sup>79</sup> *Vanderlande Indus. Nederland BV v. Int’l Trade Comm’n*, 366 F.3d 1311, 1318 (Fed. Cir. 2004) (“While extrinsic evidence can shed useful light on the relevant art . . . ‘intrinsic evidence is the most significant source of the legally operative meaning of disputed claim language.’”) (quoting *Vitronics Corp. v. Conceptoronic, Inc.*, 90 F.3d 1576, 1582 (Fed. Cir. 1996)).

<sup>80</sup> *A&P*, 340 U.S. at 152.

<sup>81</sup> U.S. Patent No. 2,242,408 col. 4 l.34–col. 6 l.6.

<sup>82</sup> *Id.* at col. 2 ll.7–10.

interpreted to offer as the invention a bottomless frame to move groceries along a counter in the same fashion billiard balls are moved on a pool table!

The Supreme Court apparently read the patent in *A&P* as a combination of independently old elements each performing its intended function; to wit, a frame having three sides combined with a counter for moving articles over the counter.<sup>83</sup> The '408 patent specification did support a new result by stating in “actual practice the provision of this arrangement has substantially reduced the time per customer for checking the goods purchased and has resulted in a substantial reduction in the number of registers required and the number of checkers.”<sup>84</sup> However, these new results could not have been attained without the open, U-shaped frame, which is a new combination of elements from which a new result flowed.<sup>85</sup> The application did not focus on this new combination of U-shaped elements in both the claims and the introduction.<sup>86</sup> Only one of the claims recited the open end new result but, indeed, all other claims read upon the prior art triangular billiard-ball rack.<sup>87</sup>

The lesson reinforced by this decision is that the entire patent should focus on the new result and present facts that satisfy the new result guideline, facts of the type Jefferson advocated.

#### *E. Applying the Presentation Category to the A&P Patent*

This paper illustrates how the *A&P* patent might have been saved from its inherent demise or, at least, have been more difficult to diminish. A series of preparation steps focus on the new result throughout the patent specification. The italicized portions indicate newly drafted portions and the bold portions are copied from the *A&P* patent, with additions underlined and deletions either double-bracketed or struckthrough.

##### *1. Understanding the Enabling Embodiment*

It is essential that every element, function, and ultimate operation of the enabling embodiment be understood and precisely described in the patent specification. This is necessary to adequately describe and claim all aspects of the invention that are commercially important and new. Everything the inventor knows should be set forth in the patent specification. The most efficient manner to proceed is to start by writing a detailed picture claim.<sup>88</sup> Using the '408 patent as a disclosure,<sup>89</sup> the following detailed picture claim is drafted using the same terminology as used in the '408 patent:

---

<sup>83</sup> *A&P*, 340 U.S. at 152.

<sup>84</sup> U.S. Patent No. 2,242,408 col. 4 ll.27–33.

<sup>85</sup> See *supra* note 59 and accompanying text.

<sup>86</sup> See U.S. Patent No. 2,242,408.

<sup>87</sup> See *id.* at col. 4 l.34–col. 6 l.6.

<sup>88</sup> Accord Robert C. Faber, FABER ON MECHANICS OF PATENT CLAIM DRAFTING § 10:1.2[F]–[G] (2010).

<sup>89</sup> See U.S. Patent No. 2,242,408.

*A counter assembly for use by a cashier and a customer in a grocery store comprising;*

*a cashier counter presenting a counter top for receiving articles of merchandise of the customer,*

*a recording cash register adjacent said cashier counter for operation by a cashier to record the articles of merchandise for each customer,*

*an extension of said cashier counter and said counter top for receiving articles of merchandise for the next customer as the cashier records the articles of merchandise for the previous customer,*

*a frame disposed on said counter top for sliding movement between a receiving position over said extension and a checkout position on said cashier counter adjacent the cashier,*

*said frame having a U-shape including a front side bar and a rear side bar joined by an end bar and being open toward said recording cash register for engaging and moving articles on said counter top from said receiving position to said check out position and followed by open sliding movement back to said receiving position for receiving articles of merchandise for another customer,*

*a stop extending upward from said extension for engaging said end bar to limit sliding movement of said frame off of said counter top in said receiving position,*

*channel members interconnecting said side bars and said counter top for guiding said sliding movement of said frame between said receiving and checkout positions, and*

*a handle extending from said frame for manually moving said frame between said positions*

In contrast to this detailed picture claim, the claims of the '408 patent are all independent and generally of the same scope with the exception of claim 6, which recites the frame as being open at one end.<sup>90</sup> Instead, the rewrite of the '408 patent will focus on claims varying in scope from the most comprehensive in detail to the broadest with intermediate dependent claims.

## *2. Analyzing, Pruning and Distilling to the Broad Claim*

To produce the broad claim the original detailed picture claim is analyzed, pruned and distilled with deletions struck through as follows:

---

<sup>90</sup> *Id.* at col. 4 l.34–col. 6 l.6.

*A counter assembly for use by a cashier and a customer in a ~~grocery~~ store comprising;*

*a cashier counter presenting a counter top for receiving articles of merchandise of the customer,*

*a recording cash register adjacent said cashier counter for operation by a cashier to record the articles of merchandise for each customer,*

*an extension of said cashier counter and said counter top for receiving articles of merchandise for the next customer as the cashier records the articles of merchandise for the previous customer,*

*a frame disposed on said counter top for sliding movement between a receiving position over said extension and a checkout position on said cashier counter adjacent the cashier,*

*said frame ~~having a U shape including a front side bar and a rear side bar joined by an end bar and being open toward said recording cash register for engaging and moving articles on said counter top from said receiving position to said check out position and followed by open sliding movement back to said receiving position for receiving articles of merchandise for another customer~~[[,]]*

*~~a stop extending upward from said extension for engaging said end bar to limit sliding movement of said frame off of said counter top in said receiving position,~~*

*~~channel members interconnecting said side bars and said counter top for guiding said sliding movement of said frame between said receiving and checkout positions, and~~*

*~~a handle extending from said frame for manually moving said frame between said positions.~~*

### 3. Dependent Claims

Although not claimed in the original '408 patent, the specific structure of the “U-shape,” “stop,” “channel members”, and “handle” were recognized and claimed in the detailed picture claim.<sup>91</sup> The detailed claim secures the recognition of these very important limitations for use in drafting additional claims, dependent or independent. For example, it is difficult to visualize the use of the frame without a handle to manually move the frame between the receiving and checkout positions. The handle would clearly further distinguish the new result from a billiard-ball rack which does not have a handle as an additional element. The frame was probably

---

<sup>91</sup> See *supra* Part V.E.1.



unmarketable without a handle. In actual usage, the handle was eventually moved to the rail closest to the cashier for manual dragging of the frame by the cashier.<sup>92</sup> A claim dependent on the broadest claim and reciting only the “handle” would have likely been a litigation stopper. Although not presented here, an array of dependent claims should be drafted to serially add to the broad claim those limitations pruned (deleted) from the detailed picture claim in drafting the broad claim.

#### 4. Detailed Picture Claim as Basis for Description

The detailed picture claim contains every specific element and attendant function of the enabling embodiment and may be copied into the specification and edited into grammatically correct sentence structure. Alternative terminology, embellishments, and environmental subject matter which fall under the umbrella of the new result covered in the broad claim should be added into the description founded upon the detailed picture claim. This step will keep the claims and description consistent to avoid ambiguity and misinterpretation of the claims. Inconsistency of terminology between the claims and the description presents a major interpretation problem, as expressed by The Court of Appeals for the Federal Circuit’s (“CAFC”) Judge Linn during oral argument in *Logan v. Hormel Foods*<sup>93</sup> when he interrupted counsel for the patentee:

This is an interesting case and it’s so typical of so many patent cases that are litigated and come up to this court. We have a term in the claim that’s in dispute . . . [and] it’s not used anywhere in the written description. If that term was used in the written description, there wouldn’t be this kind of debate. We’re left hanging. Why patents are written this way I don’t know. And then to compound the complexity, the application only has one embodiment, which of course puts into play this debate about, “Well is that just an embodiment or is that *the* invention?” We have both of these intriguing problems which are sort of self-inflicted by practitioners. I don’t know why, but they’re self-inflicted problems.<sup>94</sup>

#### 5. Drafting the Introductory Sections

As the cases will verify, one of the most egregious errors in preparing a patent application is that the introductory sections are *not* consistent with or under the umbrella of the broadest claim. Frequently, the introductory sections are much broader than the broadest claim so to be attributable to the prior art or are too

---

<sup>92</sup> *Bradley v. Great Atl. & Pac. Tea Co.*, 78 F. Supp. 388, 389–90 (E.D. Mich. 1948), *aff’d sub nom.* *Great Atl. & Pac. Tea Co. v. Supermkt. Equip. Corp.*, 179 F.2d 636, 637 (6th Cir. 1950), *rev’d*, 340 U.S. 147 (1950).

<sup>93</sup> *Logan v. Hormel Foods, Inc.*, 217 F. App’x 942, 943 (Fed. Cir. 2007).

<sup>94</sup> Recording of oral argument, *Logan v. Hormel Foods, Inc.*, 217 F. App’x 942 (Fed. Cir. 2007), available at <http://www.cafc.uscourts.gov/oral-argument-recordings/2006-1114/all>.

narrow and are read as limitations into the broadest claim.<sup>95</sup> In addition, the commercial advantages are commingled with the descriptions of the prior art and lead to confusion as to the interpretation of the claims.<sup>96</sup>

#### 6. *The Field of Invention*

The preamble of the broad claim is an excellent choice for formulating this field of invention section.

*The subject invention relates to a counter assembly for a cashier in a store.*

#### 7. *The Prior Art*

The prior-art section should include those recitations in the broad claim which are old and well known and which serve as support and/or necessary antecedents. This prior art should include only that prior art recited in the broadest claim.

*Such counter assemblies include a cashier counter presenting a counter top for receiving articles of merchandise of a customer and a recording cash register adjacent the cashier counter for operation by a cashier to record the articles of merchandise for each customer.*

The deficiencies in the prior art may be added. For this purpose, the second paragraph of the '408 patent is copied and edited to focus more precisely on the problem solved by this open-frame new result and reads as follows:

***In cash and carry stores it is the practice for the customer to gather up the goods or articles which have been selected and to approach the cashier's stand usually carrying the articles in a basket. It is necessary for the customer to stand in line and eventually his heavy basket of articles is deposited on the counter in front of the cashier checker. It is then necessary for the cashier checker to pick out the articles from the basket to record them individually on the register and sort them as they are picked out of the basket in order to group together the various articles. Many***

---

<sup>95</sup> Compare *DSW, Inc. v. Shoe Pavilion, Inc.*, 537 F.3d 1342, 1347 (Fed. Cir. 2008) (collecting cases for the proposition that claim language is given its ordinary meaning and scope absent a special definition or clarity issue), with *Edward Lifesciences LLC v. Cook Inc.*, 582 F.3d 1322, 1331–32 (Fed. Cir. 2009) (listing cases where claim scope was limited by the written description's statements of what constitutes “the present invention”), and *Computer Docking Station Corp. v. Dell, Inc.*, 519 F.3d 1366, 1375 (Fed. Cir. 2008) (limiting claim scope to “portable” computers as defined in the specification even though the term was in the preamble rather than the body).

<sup>96</sup> See, e.g., U.S. Patent No. 5,632,183 col. 1 ll.40–49 (filed Aug. 9, 1995) (describing a recent mechanism as “simple and inexpensive and easy to operate and that accomplishes the required pedal adjustment without altering further critical dimensional relationships” but merely that the “present invention represents improvements to the basic adjustable control design”).

*times where two or three cans or objects of the same type of article are sold for lump sum, such as three cans for twenty-five cents, the cashier checker must hunt through the entire basket of goods to pick out these several cans or articles. All of this is done one customer at a time as the goods of the second customer cannot be placed on the counter until the previous customer's goods are checked out and gone from the counter. As a consequence thereof considerable delay is encountered at the cashier's checker's stand due to the fact that the cashier checker must perform all of these operations while recording the price of the goods on the register. The result has been that in larger stores a great number of cashiers checkers have been required and each cashier checker must be provided with a register. Registers of this type cost several hundred dollars and as a result the store owner has been put to considerable investment in registers and considerable expense in maintaining an excessive number of cashiers checkers in order to prevent delay and dissatisfaction on the part of the customers.*<sup>97</sup>

#### 8. Summary of the Invention

The Summary section should be commensurate in scope to the broadest claim. In other words, the Summary section should include only that which is new from the broadest claim, nothing more! In some jurisdictions, the Summary of the Invention can be no broader than the broadest claim.<sup>98</sup> Drafting a Summary section broader than the broadest claim can lead to an interpretation of the broadest claim as reading on the prior art, as in the '408 patent. Conversely, as cases hereinafter illustrate, a Summary section more narrow than the broadest claim can lead to a narrowing or diminishing interpretation of the broadest claim.<sup>99</sup> Accordingly, this Summary section is prepared by copying the novel limitation from the broadest claim and appears as follows:

*The subject invention is distinguished from the prior art by an extension of the counter and the counter top for receiving articles of merchandise for the next customer as the cashier records the articles of merchandise for the previous customer and a frame disposed on the counter top for sliding movement between a receiving position over the extension and a checkout position on the cashier counter adjacent the cashier with the frame being open toward the recording cash register for engaging and moving articles on the counter top from the receiving position to the check out position and*

---

<sup>97</sup> U.S. Patent No. 2,242,408 col. 1 ll.5–35.

<sup>98</sup> *E.g.*, EUROPEAN PATENT OFFICE, IMPLEMENTING REGULATIONS TO THE CONVENTION ON THE GRANT OF EUROPEAN PATENTS, Rule 42 (14th ed., 2010), available at [http://documents.epo.org/projects/babylon/eponet.nsf/0/7bacb229e032863dc12577ec004ada98/\\$FILE/EPC\\_14th\\_edition.pdf](http://documents.epo.org/projects/babylon/eponet.nsf/0/7bacb229e032863dc12577ec004ada98/$FILE/EPC_14th_edition.pdf) (stating that the description shall disclose the invention as claimed and describe at least one way of carrying out the invention claimed).

<sup>99</sup> See *infra* Part VII.E.

*followed by open sliding movement back to the receiving position for receiving articles of merchandise for another customer.*

### 9. Advantages of the Invention

The advantages of the invention should be directly attributable to and under the umbrella of the new result expressed in the broadest claim. For example, an advantage attributable to the more specific handle recited in a claim more detailed than the broadest claim should not be recited in this section but should be recited with the description of the handle in the description section. Instead of being posted in the introductory sections of the '408 patent, the last paragraph in the description of the '408 patent recited the following advantages:

***In actual practice the provision of this arrangement has substantially reduced the time per customer for checking the goods purchased and has resulted in a substantial reduction in the number of registers required and the number of checkers which are necessary to take care of a given number of customers.***<sup>100</sup>

In order to more directly tie the advantages to the broadest claim, the above advantage would be edited to read:

***Eliminating the wait time for the next customer to place goods on the counter and using the open frame to move the next customer's goods quickly into position has substantially reduced the time per customer for checking the goods purchased and has resulted in a substantial reduction in the number of registers required and the number of ~~cashiers~~ ~~checkers~~ which are necessary to take care of a given number of customers.***

### F. The A&P Opinion that Might Have Been

The new result based upon the open frame is focused upon throughout the re-written '408 patent. All of the claims recite an open frame. Consistent terminology from the claims is used in the description. Most importantly, the introductory sections focus on the open frame and the advantages are directly under the umbrella of and resulting from the open frame.

The opinion of the Supreme Court in *A&P* is rational and correct if it is based totally upon the intrinsic patent specification because a billiard-ball rack meets the objectives of all but one claim of the '408 patent.<sup>101</sup> Except for a copy of claim 6 that was included along with claims 4 and 5 in footnote 1, the Supreme Court opinion did

---

<sup>100</sup> U.S. Patent No. 2,242,408 col. 4 ll.27-33.

<sup>101</sup> *Id.* at col. 4 l.34-col. 6 l.6.

not mention the “open” frame.<sup>102</sup> Instead the court dismissed the extension of the counter: “[W]ere we to treat the extension as adequately disclosed, it would not amount to an invention.”<sup>103</sup> The Court summarized:

Stated without artifice, the claims assert invention of a cashier’s counter equipped with a three-sided frame, or rack, with no top or bottom, which, [when] pushed or pulled, will move groceries deposited within it by a customer to the checking clerk and leave them there when it is pushed back to repeat the operation. It is kept on the counter by guides. That the resultant device works as claimed, speeds the customer on his way, reduces checking costs for the merchant, has been widely adopted and successfully used, appear beyond dispute.<sup>104</sup>

The court opined:

The negative rule accrued from many litigations was condensed about as precisely as the subject permits in *Lincoln Engineering Co. of Illinois v. Stewart-Warner Corp.*: “The mere aggregation of a number of old parts or elements which, in the aggregation, perform or produce no new or different function or operation than that theretofore performed or produced by them, is not patentable invention.”<sup>105</sup>

Accordingly, if the *A&P* opinion is evaluated from the standpoint of a patent attorney skilled in interpreting patents to cover an open, three-sided frame taking into consideration all of the extrinsic evidence presented at trial, the court made an error and the decision is wrong, as Cole maintains.<sup>106</sup> However, if the opinion is evaluated from the standpoint of a Federal Judge accustomed to referring to base documents such as commercial contracts and who literally relies upon only the intrinsic patent as a contract, the rationale of the Supreme Court in *A&P* is correct.

Had the ’408 patent been focused on the new result throughout the various sections as in the focused re-written *A&P* patent, the Supreme Court might have addressed the “open” frame. One can speculate that if a claim in the *A&P* patent had recited a “handle” to manually move the frame, a necessary element to the commercial success of the invention, this case would not have been litigated!

#### VI. *GRAHAM V. JOHN DEERE CO.*—ANOTHER FAILURE IN RECOGNITION AND PRESENTATION

U.S. Patent No. 2,627,798 (“the ’798 patent”),<sup>107</sup> issued to W. T. Graham and at issue in the famous U.S. Supreme Court decision of *Graham v. John Deere Co.*,<sup>108</sup>

---

<sup>102</sup> See *A&P*, 340 U.S. at 148 n.1.

<sup>103</sup> *Id.* at 150.

<sup>104</sup> *Id.* at 149.

<sup>105</sup> *Id.* at 151 (citation omitted).

<sup>106</sup> See Cole, *supra* note 38.

<sup>107</sup> U.S. Patent No. 2,627,798 (filed Aug. 27, 1951).

<sup>108</sup> 383 U.S. 1 (1966).

parallels the patent in *A&P* in being slim on recognition of and devoid of presentation of a new result.

*A. Graham’s Prior Art ’811 Patent*<sup>109</sup>

In his own prior art patent, U.S. Patent No. 2,493,811 (“the ’811 patent”),<sup>110</sup> Graham presented a mechanism for dragging a tiller or plow shoe over the ground while allowing the shoe to move up and down in response to hitting rocks, or the like.<sup>111</sup> A shank supported the shoe and extended upwardly in a semi-circle and then forward over a hinge plate which was pivotally supported on a fixed member at a pivot axis to allow the shank to move up and down.<sup>112</sup> A spring urged the hinge plate upwards to urge the shoe into the ground but compressed to allow pivoting movement of the hinge plate about the pivot axis in response to the shoe hitting a rock.<sup>113</sup>

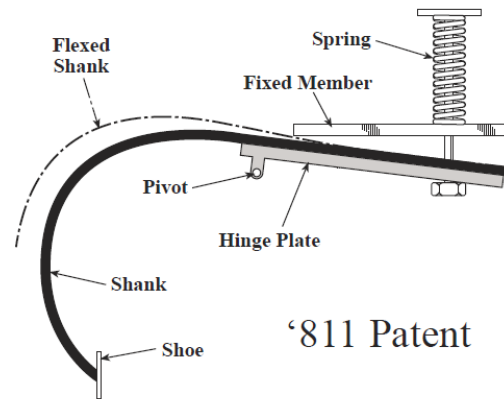

The Court acknowledged in footnote 11 that the shank in the ’811 patent was forced “up against the underside of the rear of the upper plate” (i.e., the fixed member).<sup>114</sup> “The upper plate thus provided the fulcrum about which the hinge was pried open.”<sup>115</sup> This combination was argued during prosecution of the ’798 patent before the PTO as causing wear to the underside of the fixed member thereby causing frequent replacement of the fixed member.<sup>116</sup> As the flexed position is shown in dashed lines in the above sketch, a stress point is created at the “fulcrum” where the shank leaves the top of the hinge plate and engages the fixed member.<sup>117</sup> However, Graham presented “not one line of evidence in this record that there was any problem of shank breakage or bending with the Graham ’811.”<sup>118</sup> Graham never argued the shank would bend about the “fulcrum” to create concentrated stress point much like bending a metal wire back and forth until it breaks.<sup>119</sup> In accordance with

<sup>109</sup> I shared this section with Paul Cole, who—to my delight and in his very clever use of words from the *Graham* opinion—commented on this section by stating: “I think your discussion of *Graham* is *ground-breaking* and of staggering importance. Potentially, it will *rock* the whole profession.”

<sup>110</sup> U.S. Patent No. 2,493,811 (issued Feb. 26, 1947).

<sup>111</sup> *Id.* at col. 1 ll.44–49.

<sup>112</sup> *Id.* at figs. 4–7.

<sup>113</sup> *Id.* at col. 5 l.25–col. 6 l.28.

<sup>114</sup> *Graham v. John Deere Co.*, 383 U.S. at 23 n.11.

<sup>115</sup> *Id.*

<sup>116</sup> *Id.* at 22–23, 23 n.11.

<sup>117</sup> *Id.* at 23–24.

<sup>118</sup> Brief for Respondents at 38; *Graham*, 383 U.S. 1 (No. 11), 1965 WL 115657, at \*38.

<sup>119</sup> *Graham*, 383 U.S. at 25.

the admitted operation of the '811 patent, the combination of the '811 patent presented higher stress at the fulcrum than along the remainder of the shank.<sup>120</sup>

### B. The Graham '798 Patent in Issue

In Graham's second patent, the '798 patent at issue before the U.S. Supreme Court, the shank was supported on the bottom surface of the hinge plate.<sup>121</sup> In contradistinction to being on the top surface of the hinge plate in the '811 patent, the shank in the '798 patent ran under the length of the hinge plate rearward through a stirrup defined by a strap.<sup>122</sup> The shank was attached to the bottom of the hinge plate,

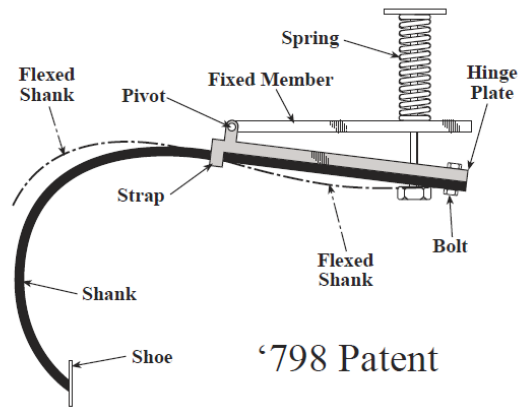

ran through the stirrup (strap), and curved several feet down to the tiller shoe or plow.<sup>123</sup> In this combination of elements, the shank could flex and bow away from the bottom surface of the hinge plate (as shown in dashed lines) using the stirrup as a fulcrum between the oppositely bowed lengths of the shank.<sup>124</sup>

### C. The Deficiencies in Recognition and Presentation

The new result of eliminating the stress point by placing the shank on the bottom of the hinge plate with the shank free to flex along the length of the hinge plate is not mentioned in the presentation of the '798 patent.<sup>125</sup> In fact, both claims in the '798 patent are contrary to the flexing of the shank from the underside of the hinge plate by reciting "a bolt . . . maintaining the upper surface of the shank in constant continuous contact with the undersurface of said plate."<sup>126</sup>

The two claims in the '798 patent are very long and detailed and required study to ferret out structural distinctions over the inventor's prior '811 patent. The two claims used terminology not found in the description, e.g., the "lower hinge plate," referred to in the appeal was designated the "movable part" in the description and

<sup>120</sup> *Id.* at 23–24, 25 n.13.

<sup>121</sup> *Id.* at 20.

<sup>122</sup> *Id.* at 22.

<sup>123</sup> *Id.* at 19–21.

<sup>124</sup> *Id.* at 23–24.

<sup>125</sup> *See id.* at 23; U.S. Patent No. 2,627,798 (filed Aug. 27, 1951).

<sup>126</sup> U.S. Patent No. 2,627,798 col. 5 l.12–col. 6 l.44.

the “attaching member” in the claims.<sup>127</sup> The clearest recitation in the claims of the new combination was, “whereby the plate portion of the shank attaching member is between the shank and the fixed member,”<sup>128</sup> wherein the “attaching member” is the hinge plate as labeled above.<sup>129</sup>

In addition to having deficient claims, the attributes set forth in the introductory section of the ’798 patent are sufficiently broad to also apply to the structure of the previous ’811 patent.<sup>130</sup> There was no recognition of a new result flowing from the flexing of the shank away from the hinge plate let alone a proper presentation. This fault occurred in the preparation of the application. The placement of the shank under the hinge plate was done for a reason, and it appears that the patent preparer did not ascertain that reason. The reason would have led to recognition of a new result.<sup>131</sup>

#### *D. Advocacy vs. Presentation*

Because the introductory sections of the ’798 patent did not present a new result attributable only to the new structure, the new result was introduced at trial and in the appeal.<sup>132</sup> Here the patentee argued that the new structure permits the shank to flex under stress for its entire length.<sup>133</sup> The Court commented:

Petitioners’ argument basing validity on the free-flex theory raised for the first time on appeal is reminiscent of *Lincoln Engineering Co. of Illinois v. Stewart-Warner Corp.*, where the Court called such an effort “an afterthought.” No such function is hinted at in the specifications of the patent. *If this were so vital an element in the functioning of the apparatus, it is strange that all mention of it was omitted.* No “flexing” argument was raised in the Patent Office. Indeed, the trial judge specifically found that “flexing is not a claim of the patent in suit . . .” and would not permit interrogation as to flexing in the accused devices. Moreover, the clear testimony of petitioners’ experts shows that the flexing advantages flowing from the ’798 arrangement are not, in fact, a significant feature in the patent.<sup>134</sup>

Graham’s expert did state “I think this flexing will reduce the maximum stress at the point of pivot there, where the maximum stress does occur. . . . I don’t know

---

<sup>127</sup> See *id.* at col. 3 ll.63–75, col. 5 ll. 25–54, col. 6 ll.8–44.

<sup>128</sup> *Id.* at col. 5 ll.33–35.

<sup>129</sup> *Id.* at fig. 1.

<sup>130</sup> Compare *id.* at col. 1 ll.1–27 (describing the objects of the invention), with U.S. Patent 2,493,811 (filed Jan. 10, 1950) (accomplishing the objects of the ’798 patent).

<sup>131</sup> See *Graham v. John Deere Co.*, 383 U.S. 1, 25 (1966) (stating that the flexing argument being raised for the first time on appeal appears to be “an afterthought” because it “is strange that all mention of [a vital element] was omitted”).

<sup>132</sup> *Id.* at 23.

<sup>133</sup> *Id.*

<sup>134</sup> *Id.* at 25 (emphasis added) (omission in original) (citations omitted).



how much.”<sup>135</sup> The Court regarded the “flexing” issue to be one of advocacy instead of fact, and inferred that if the flexing issue had been submitted in the original patent application, then the flexing issue could have been deemed a fact.<sup>136</sup> Accordingly, the Court found all of the elements to be known in the prior art, which included a second reference not before the PTO to show a stirrup. The only difference was the rearrangement of the elements, i.e., repositioning the shank from the top surface of the lower hinge plate to the lower surface without a new result. The Supreme Court stated, “[A] person having ordinary skill in the prior art, given the fact that the flex in the shank could be utilized more effectively if allowed to run the entire length of the shank, would immediately see that the thing to do was what Graham did, i.e., invert the shank and hinge plate.”<sup>137</sup>

The Presentation of New Result Facts guideline is verified by the *Graham* decision, “the new result and supporting facts should not be withheld from the application for submission during prosecution or litigation, where they will likely be regarded as advocacy instead of fact.”<sup>138</sup> Paul Cole makes these points, confirming the importance of the facts proving a new result in the patent application as distinguished from being withheld and presented later in litigation:

It is apparent that judges, and especially non-specialist judges such as those in the U.S. District Courts and the Supreme Court, are markedly unimpressed with features whose ingenuity is not mentioned in the patent specification.<sup>139</sup>

and

A further source of unanimity between the US and the UK courts is a dislike of features given no prominence in the specification of the granted patent, but seized on during litigation as the key to inventive step. At the least, every feature from which an advantage flows should find its way into main or subsidiary claims. Very preferably the new functions, new results or other advantages should be highlighted and explained in the supporting description, because their credibility at the priority or filing date is many times greater than it is at [sic] if first identified post-grant.<sup>140</sup>

He makes this point in the following quote:

The positive indications that we can derive from the *Graham* and the *Windsurfer* tests as applied in practice are that judges are much more impressed with the underlying *technical facts* than they are with the surrounding circumstances, that they are looking for real advantages of an *unexpected* character, and that alleged *advantages unsupported* in the

---

<sup>135</sup> *Id.* at 25 n.13.

<sup>136</sup> *Id.* at 25.

<sup>137</sup> *Id.*

<sup>138</sup> See *supra* Section IV.

<sup>139</sup> PAUL COLE, FUNDAMENTALS OF PATENT DRAFTING 27 (2006).

<sup>140</sup> *Id.* at 37.

patent application as filed and only identified by hindsight lack persuasive power.<sup>141</sup>

The case law is stacked against a patent sent to the patent office on a fishing expedition without being focused on a new result, which is first presented later in litigation. “To await litigation is—for all practical purposes—to debilitate the patent system.”<sup>142</sup>

### *E. The Preparation Steps Applied to the Graham ’798 Patent*

There is no certainty that the Supreme Court would have deemed a presentation in the patent of changing the distribution of stress along the shank a sufficient new result to justify the patent. However, an orderly presentation of the slimly recognized new result could have made attack on the patent more difficult. Certainly, an array of dependent claims progressively more specifically reciting the new result would have given the infringer and the courts more pause in dismissing the patent.

#### *1. The Restructured Graham Patent Claims*

In the first instance, a detailed or picture claim could have been drafted to separate the new placement of the shank to extend along the bottom of the hinge plate and through a stirrup or strap from the old elements by a characterized by clause.

This picture claim would have been analyzed, pruned, and distilled to a characterized by clause in the broadest claim to recite the shank as extending along the bottom of the hinge plate and being flexible away from and along the hinge plate. That broad claim should have been something like this:

1. *A plow assembly of the type including ground breaking tools to heave soil for forming furrows in a field, said assembly comprising;*

*a fixed member,*

*a hinge plate having an upper surface facing said fixed member and an oppositely facing lower surface and being elongated to extend between a forward end and a rear end,*

*a pivot at said rear end of said hinge plate pivotally interconnecting said hinge plate and said fixed member for allowing rotational movement of said hinge plate relative to said fixed member,*

---

<sup>141</sup> *Id.* at 29 (emphasis added).

<sup>142</sup> *Graham v. John Deere Co.*, 383 U.S. 1, 18 (1966).

*a shank extending from said forward end of said hinge plate along said hinge plate past said rear end of said hinge plate and said pivot and into a rearward and downward curve to a plow support for allowing said shank to rotate with said hinge plate about said pivot in response to movement of said shank into and out of the soil,*

*a spring mechanism interconnecting said forward end of said hinge plate and said fixed member for yieldably urging said shank and said hinge plate to rotate about said pivot to a soil engaging position to break the soil with a plow attached to said plow support, and characterized by*

*a connection securing said shank to said lower surface of said hinge plate to define a fulcrum and allow said shank to flex away from said lower surface of said hinge plate about said fulcrum as said rearward and downward curve moves upwardly.*

Dependent claims would have incrementally added elements to the broadest claim, e.g., the fulcrum strap. A major deficiency was that the patent contained no dependent claims to further specify structure.<sup>143</sup> Analogous to the handle attached to the frame in the '408 patent, the fulcrum strap or stirrup (or an equivalent) could have been covered in a dependent claim:

*2. An assembly as set forth in claim 1 wherein said connection includes a fulcrum strap underlying said rear end of said shank to define said fulcrum for said shank to flex away from said lower surface of said hinge plate in response to said upward movement of said rearward and downward curve of said shank relative to said fulcrum strap.*

It is respectfully submitted that this claim 2 could have been a potential litigation stopper in the same manner as the “handle” dependent claim in the '408 patent.

## *2. The Graham Patent Description*

The description should have been drafted from the picture claim to make sure the terminology was consistent from the claims through the description. This would have eliminated the inconsistency in referring to the same element as the “lower hinge plate” and “movable part” in the description and the “attaching member” in the claims.<sup>144</sup>

<sup>143</sup> See U.S. Patent No. 2,627,798 col. 5 l.12–col. 6 l.44 (filed Aug. 27 1951).

<sup>144</sup> See *id.* at col. 3 ll.63–75, col. 5 ll. 25–54, col. 6 ll.8–44.

### 3. *The Graham Patent Introductory Sections*

The field of the invention could have been copied from the preamble of the broadest claim to read:

*The subject invention relates to a plow assembly of the type including ground breaking tools to heave the soil for forming furrows in a field.*

The prior art section could have been copied from the elements (sub-paragraphs) of the broadest claim preceding the characterized by clause. All that was needed as antecedents for the “characterized by” in the broadest claim were the fixed member, a hinge plate pivotally connected to the fixed member, and a shank supported by the hinge plate. A reference should have been made to the prior art ’811 patent disclosing these elements to be old and well known. It could have read:

*Such a plow assembly of the type to which the subject invention pertains is disclosed in prior art patent 2,493,811 granted to the inventor named herein and includes a fixed member and a hinge plate presenting an upper surface facing the fixed member and an oppositely facing lower surface. The hinge plate is elongated to extend between a forward end and a rear end with a pivot at the rear end of the hinge plate pivotally interconnecting the hinge plate and the fixed member for allowing rotational movement of the hinge plate relative to the fixed member. A shank extends from the forward end of the hinge plate along the hinge plate past the rear end of the hinge plate and the pivot and into a rearward and downward curve to a plow support for allowing the shank to rotate with the hinge plate about the pivot in response to movement of the shank into and out of the soil. A spring mechanism interconnects the forward end of the hinge plate and the fixed member for yieldably urging the shank and the hinge plate to rotate about the pivot to a soil engaging position to break the soil with a plow attached to the plow support.*

Bending a metal wire back and forth rapidly will stress, fatigue and break it.<sup>145</sup> Similarly, the shank on top of the hinge plate in the ’811 patent is subject to such a point of stress just as the shank leaves the upper surface of the hinge plate under the pivot.<sup>146</sup> A description of this problem could have been inserted into the prior art section as follows:

*Although the assembly of the ’811 patent works in many assemblies where the selection of materials is not a factor, there are materials that are desirable to use for the shank which cannot withstand the bending stress that may occur in the shank at the point where the shank extends in a cantilevered fashion from the rear end of the hinge plate. Any up and down movement relative to the soil of the downwardly-and-rearwardly-extending*

---

<sup>145</sup> WEBSTER’S THIRD NEW INTERNATIONAL DICTIONARY OF THE ENGLISH LANGUAGE UNABRIDGED 383 (Philip Babcock Gove et al. eds., 2002).

<sup>146</sup> *Graham*, 383 U.S. at 23 n.11; see U.S. Patent No. 2,493,811.

*shank creates concentrated stresses in the shank at a point adjacent the rear end of the hinge plate and the pivot. In the same manner as a metal wire will fatigue in response to repeated bending back and forth, the shank can, depending upon the strength of the metal, fatigue and break at the stress point between the pivot and hinge plate.*

The summary of the invention could have recited the characterized by clause of the broadest claim to read:

*The subject invention provides such an assembly characterized by a connection securing the shank to the lower surface of the hinge plate to define a fulcrum and allow the shank to flex away from the lower surface of the hinge plate as the rearward and downward curve moves upwardly.*

The advantages of the invention might have recited the prevention of over stressing one position along the shank to thereby increase the useful life of the shank. This section could have read as follows:

*The subject invention allows flexing of the shank along the entire length of the lower surface of the hinge plate to prevent weakening and fatigue of the shank due a concentration of stress along the shank. A concentrated stress point is potentially eliminated as the shank pivots about a fulcrum in the same fashion as teeter-totter balances on its fulcrum.*

There is no guarantee that such a reconstructed patent would have avoided litigation or invalidity, but it certainly would have reduced issues and made litigation more difficult. The disavowing claim limitation of the “shank in constant and continuous contact with the plate” and absolutely no mention of “flexing” in the patent, turned the litigation into a battle of experts. The record will show this battle was clearly won by the eminent Clarence Fishleigh,<sup>147</sup> with whom I had the pleasure of working. At a minimum, a proper presentation would have focused the issue more precisely on whether or not the benefit of eliminating the concentration of stress was a new result sufficient to justify the exclusive right in a patent.

## VII. THE PATENT PREPARATION STEPS DERIVED FROM THE CASES

The mechanical steps to prepare a patent application in a safe harbor must include the recognition and presentation of the new result, not only in the claims, but in all sections of the patent specification.

---

<sup>147</sup> See Brief for Respondents at 13–14, 30–36, *Graham v. John Deere Co.*, 383 U.S. 1 (1966) (No. 11), 1965 WL 115657, at \*13–14, \*30–36.

### *A. Picture Claim*

A picture claim is drafted to make sure every line of the drawings and/or every element and detail of the preferred embodiment of the invention is understood in structure and operation.<sup>148</sup>

### *B. Broad Claim*

The picture claim is analyzed, pruned, distilled, and edited into the broadest claim to isolate and distinguish the point of novelty from the prior art.

### *C. Dependent Claims*

A series of dependent claims are drafted with each dependent claim adding a limitation from the picture claim.<sup>149</sup> The language of the broad and dependent claims is reconciled with the language of the picture claim so that the picture claim ends up with all of the recitations of all of the other claims.

### *D. Copying the Claims as a Core for the Description*

Since the picture claim contains the terminology of all other claims, the picture claim may be copied into the specification and edited into grammatically correct sentence structure while adding alternative terminology, embellishments, and environmental descriptions which fall under the umbrella of the new result covered in the broadest claim. If no picture claim is drafted, all of the claims should be copied into the description.

### *E. Drafting the Introductory Sections*

The introductory sections must be commensurate with the broad claim. The claims of many patents are interpreted and diminished in scope based on statements made in the introductory sections of the patent.<sup>150</sup> It is important that the introductory sections be no narrower or broader in scope than the broadest claim.

---

<sup>148</sup> U.S. PATENT & TRADEMARK OFFICE, U.S. DEP'T OF COMMERCE, MANUAL OF PATENT EXAMINING PROCEDURE § 706 I (8th ed., 8th rev. 2010).

<sup>149</sup> See 37 C.F.R. § 1.75(c) (2011).

<sup>150</sup> See *supra* note 95 and accompanying text.

### *1. Drafting the Field of Invention*

A sentence is drafted under the heading *1.) Field of the Invention* stating the field of art to which the invention contributes. This is typically the preamble of the picture claim and/or claim 1, or paraphrased from the sub-class definition.

### *2. Drafting the Description of the Prior Art*

A description of specific prior art is added under the heading *2.) Description of the Prior Art* by copying the elements in the broadest claim preceding the “characterized by” clause. Prior art patent numbers should be added to show such specific elements to be old and well known. This section should contain nothing more.

### *3. Drafting the Summary of the Invention*

That portion of the broadest claim following the “characterized by” clause is copied under the heading Summary of the Invention and edited into grammatically correct sentence structure. This section should always remain commensurate with the novelty expressed in the broadest claim, even after amendment. In some instances the entire broad claim may be copied into the summary section.

### *4. Drafting the Advantages of the Invention*

At least one paragraph is drafted under the heading Advantages of the Invention reciting the advantages of the invention, which are frequently the advantages provided by the inventor. This is the section to recite and/or embellish the new result in sufficient detail to justify the grant of the exclusive right afforded by a patent in accordance with the ideals of Jefferson, i.e., the benefit to society to justify the grant of the patent. To avoid a more narrow interpretation of the broadest claim, the advantages recited in this advantages section should be attributable to the broadest claim and advantages provided by more specific claims should be recited in the description section.

## VIII. ADDITIONAL CASES VALIDATING THE PREPARATION STEPS

Many more patents might have avoided demise in the storm of litigation had the original patent application been prepared in accordance with the architectural methodology set forth herein. As Cole states, “Judges have the recurring characteristic that they treat ill-prepared documents dismissively and patent specifications are no exception, as the . . . U.S. Supreme Court . . . demonstrates.”<sup>151</sup>

---

<sup>151</sup> See COLE, *supra* note 139, at 243.

In addition to *A&P* and *Graham*, other cases support the use of these mechanical steps for preparing a patent application, as outlined below.

*A. The Supreme Court has Recognized a Properly Presented  
New Result—Webster Loom Co. v. Higgins*

In contradistinction to the *Hotchkiss-A&P-Graham-KSR* no new result axis, a combination of independently old elements is deemed a non-obvious inventive step when a new result is recognized and presented in the patent. In *Webster Loom Co. v. Higgins*,<sup>152</sup> the Supreme Court noted that the patent described a complex weaving loom that was made up of independently old elements from prior art assemblies and that a known pusher was substituted for a latch riding on a wire-bar.<sup>153</sup> The Court said:

It may be laid down as a general rule, though perhaps not an invariable one, that if a new combination and arrangement of known elements produce *a new and beneficial result*, never attained before, it is evidence of invention. *It was certainly a new and useful result to make a loom produce fifty yards a day when it never before had produced more than forty; and we think that the combination of elements by which this was effected, even if those elements were separately known before, was invention sufficient to form the basis of a patent.*<sup>154</sup>

As the above quote makes clear, the Court found that a combination of independently old elements was patentable because the combination produced a new result, i.e., a 25% increase in weaving production from forty to fifty yards per day.<sup>155</sup> The Supreme Court found facts showing a new result, reversed the lower court, and held the patent valid.<sup>156</sup>

The primary difference between the *Webster Loom* patent and the patents in *Hotchkiss*, *A&P*, *Graham*, and *KSR* is that the introductory section of the *Webster Loom* patent precisely recited the combination the Supreme Court relied upon as the combination of elements covered by the patent claim.<sup>157</sup> In fact, the Supreme Court quoted this entire section of the patent in its opinion.<sup>158</sup> Even though the 25% increase in weaving production was not specifically recited in the patent, the introductory section recited the operational advantages or differences of the combination, which in turn resulted in the new result.<sup>159</sup> The introductory section of the patent did not broadly allude to inventing a new loom, but precisely recited the new combination and operation of independently old elements that provide the new

---

<sup>152</sup> 105 U.S. 580 (1881).

<sup>153</sup> *Id.* at 589.

<sup>154</sup> *Id.* at 591–92 (emphasis added).

<sup>155</sup> *See id.*

<sup>156</sup> *Id.* at 599.

<sup>157</sup> *See* U.S. Patent No. 130,961 col. 1 (issued Aug. 27, 1872).

<sup>158</sup> *Webster Loom*, 105 U.S. at 581–82.

<sup>159</sup> *Id.*



result.<sup>160</sup> However, as other cases suggest, the 25% increase in weaving production should have been presented as a fact in the introductory section and not left to advocacy during litigation.

The principle from *Webster Loom* is that when the entire patent is precisely focused around recognition and presentation of a new result in the claims, as well as in the introductory sections, it is more likely to be in a safe harbor.

### *B. An Entire Patent Focused on a New Result—In re Adams*

The *In re Adams*<sup>161</sup> decision resulted from an appeal to the U.S. Court of Customs and Patent Appeals (“CCPA”) that reversed a rejection by the PTO and resulted in U.S. Patent 3,286,477 to Harold W. Adams.<sup>162</sup> Prior to the Adams’ invention, round containers were moved in a helical path about an axis in a cooler while liquid water sprayed radially onto the containers for cooling by evaporation.<sup>163</sup> The new combination of independently old elements substituted aerated cooling water by introducing a gaseous medium into a cooling liquid to form a foam coolant to cover the surface of the cans without splashing. As distinguished from the prior art, the cans were cooled 26% more efficiently with aerated water.<sup>164</sup> A first prior art reference disclosed an apparatus for cooling containers by directing a spray of liquid water radially onto the containers.<sup>165</sup> The second prior art reference disclosed a water aerator connected to a faucet to prevent running water from splashing when it hit a user’s hands, but recited nothing about using aerated water for cooling.<sup>166</sup> The PTO argued that heat transfer is inherent in an aerated spray, making it obvious to substitute an aerated spray for a liquid spray.<sup>167</sup> However, no references were found that showed aerated water being used in a heat transfer application.<sup>168</sup> Though all of the elements in the combination were found to be independently old in the prior art, the use of the aerated water produced a new and unpredicted result of a 26% increase in the cooling rate.<sup>169</sup>

The significance of this case is that the patent application precisely recognized and presented the new result throughout the patent.<sup>170</sup> The claims were clearly and distinctly directed to cooling round containers with a foam coolant generated by introducing a gas into water.<sup>171</sup> The introductory section of the patent set forth the prior art of cooling by spraying round containers with water, specifically stating that “[i]t has been discovered that replacement of fan-type spray nozzles with aerating or

---

<sup>160</sup> *Id.*

<sup>161</sup> *In re Adams*, 356 F.2d 998 (C.C.P.A. 1966).

<sup>162</sup> *Id.* at 1003; U.S. Patent No. 3,286,477 (filed Jan. 6, 1961).

<sup>163</sup> *Adams*, 356 F.2d at 999.

<sup>164</sup> *Id.* at 1000.

<sup>165</sup> *Id.* at 999–1000.

<sup>166</sup> *Id.* at 1000.

<sup>167</sup> *Id.* at 1002.

<sup>168</sup> *See id.*

<sup>169</sup> *Id.* at 1000 (emphasizing the amount of time that had passed between the prior art and Adams’ invention).

<sup>170</sup> *See* U.S. Patent No. 3,286,477 col. 1 ll.27–37, col. 3 ll.55–66 (filed Jan. 6, 1961).

<sup>171</sup> *Id.* at col. 4 l.15–col. 5 l.4.

foam nozzles greatly improves the cooling efficiency.”<sup>172</sup> Clearly, the introductory section acknowledged a substitution of one element for another, i.e., an aeration nozzle for a spray nozzle. In addition, the specification recited test data to support the improved cooling efficiency and specifically recited the 26% increase in the cooling rate.<sup>173</sup>

The successful patent in *Adams* masterfully framed a combination of independently old elements that produced a new and an unexpected result. The claims clearly and distinctly pointed out a specific combination of elements that provided the new result and facts supporting the new result were specifically and exclusively presented in the introduction of the application.

### C. Need for a Picture Claim—Cannon Rubber v. The First Years<sup>174</sup>

U.S. Patent 5,749,850 discloses two breast pump embodiments.<sup>175</sup> The Court’s task was to construe the claim language regarding a pressure regulating diaphragm.<sup>176</sup>

The first embodiment is described as having a diaphragm “mounted directly in the body.”<sup>177</sup> The second embodiment is described as the “diaphragm is mounted thereon” referring to the body.<sup>178</sup> The diaphragm in the accused product lapped over the upper rim of the body of the pump like in the second embodiment.<sup>179</sup> Claim 1 recited “a deformable diaphragm disposed in the body.”<sup>180</sup> The district court interpreted this to mean disposed “entirely within the body of the pump.”<sup>181</sup> Neither party questioned the district court’s determination that a portion of the diaphragm of the second embodiment is located outside of the body of the pump.<sup>182</sup> The CAFC opined:

Although the phrase “mounted thereon,” which indicates that at least a portion of the diaphragm is on the outer surface of the body of the pump, may have a somewhat different meaning than the phrase “diaphragm disposed in the body,” the two phrases are not mutually exclusive, *viz.*, a diaphragm “mounted thereon” the body can also be a “diaphragm disposed in the body,” as the second embodiment of the specification shows. Thus, the specification uses different words to highlight the different ways that a diaphragm may be placed in the body of the pump. Moreover, contrary to TFY’s position, the specification unambiguously uses the phrase “in the

---

<sup>172</sup> *Id.* at col. 1 ll. 27–30.

<sup>173</sup> *Id.* at col. 3 ll. 3–37.

<sup>174</sup> *Cannon Rubber Ltd. v. The First Years, Inc.*, 163 Fed. App’x 870 (Fed. Cir. 2005).

<sup>175</sup> U.S. Patent 5,749,850 (filed Mar. 21, 1996).

<sup>176</sup> *Cannon Rubber*, 163 Fed. App’x at 874.

<sup>177</sup> U.S. Patent 5,749,850 col. 4 ll.51–52.

<sup>178</sup> *Id.* at col. 6 l.16.

<sup>179</sup> *Cannon Rubber*, 163 Fed. App’x at 873.

<sup>180</sup> U.S. Patent 5,749,850 col. 8 l.62.

<sup>181</sup> *Cannon Rubber Ltd. v. The First Years, Inc.*, No. 03-4918, 2004 WL 2533720, at \*4 (N.D. Ill. Sept. 28, 2004), *vacated*, 163 Fed. App’x 870 (Fed. Cir. 2005).

<sup>182</sup> *Cannon Rubber*, 163 Fed. App’x at 874.

body” in the “Summary of the Invention” section to refer to diaphragms that are contained both entirely and partially in the body of the pump. And the fact that the specification contains figures of embodiments that are both entirely and partially in the body is a strong indication that the claims were intended to encompass both.<sup>183</sup>

It is important to note that the Summary section of the patent generically refers to the mounting of the diaphragm by reciting a “body housing a deformable diaphragm”<sup>184</sup> and generically describes the diaphragm as “releasably retained in the body”<sup>185</sup> followed by a more specific description of each species.<sup>186</sup> Nothing was found in the prosecution history to disclaim all but “entirely within” the body as the meaning.<sup>187</sup> There are no dependent claims in the ’850 patent differentiating between the two species, i.e., no species claims.<sup>188</sup>

This interpretation problem would have been avoided by drafting a detailed picture claim generic to both embodiments followed by species claims of the two respective embodiments. Such a detailed claim would have forced recognition of two different species and a need to use different descriptive language for the two species. For example, “a diaphragm supported by said body” could have been used generically with one species being described and claimed as “disposed entirely within said body” and the second species being described and claimed as “disposed partially within said body.”

The broad claim would have then recited the generic terminology which would have been carried over into the Summary section. In addition, there would have been clear claim differentiation with separate species claims. As a result of using the recognizing and presenting steps suggested herein, this litigation interpretation issue might have been avoided.

#### *D. Claims Limited by Introductory Sections: Honeywell v. ITT*

The issue in *Honeywell International, Inc. v. ITT Industries, Inc.*<sup>189</sup> was whether U.S. Patent No. 5,164,879<sup>190</sup> covered a generic fuel system component or a specific fuel filter.<sup>191</sup> The Abstract section of the ’879 patent states “[a] fuel system component,” but leads off the background with: “This invention relates to a fuel filter . . .”<sup>192</sup> Claim 1 again recites a “[f]uel system component.”<sup>193</sup> The CAFC stated:

---

<sup>183</sup> *Id.* at 875 (citation omitted).

<sup>184</sup> U.S. Patent No. 5,749,850 col. 1 l.53.

<sup>185</sup> *Id.* at col. 2 l.16.

<sup>186</sup> *Id.* at col. 2 ll.1–7, col. 2 ll.16–25.

<sup>187</sup> *Cannon Rubber*, 163 Fed. App’x at 875.

<sup>188</sup> *See* U.S. Patent No. 5,749,850 col. 7 l.53–col. 10 l.32.

<sup>189</sup> *Honeywell Int’l, Inc. v. ITT Indus., Inc.*, 452 F.3d 1312 (Fed. Cir. 2006).

<sup>190</sup> U.S. Patent No. 5,164,879 (filed Jul. 1, 1991).

<sup>191</sup> *Honeywell*, 452 F.3d at 1317.

<sup>192</sup> U.S. Patent No. 5,164,879 Abstract, col. 1 ll.8–9.

<sup>193</sup> *Id.* at col. 4 l.45.

We agree with the district court that the claim term “fuel injection system component” is limited to a fuel filter. In *Phillips v. AWH Corp.*, this Court recognized that “claims ‘must be read in view of the specification, of which they are a part.’” . . . Here, the written description uses language that leads us to the conclusion that a fuel filter is the only “fuel injection system component” that the claims cover, and that a fuel filter was not merely discussed as a preferred embodiment. On at least four occasions, the written description refers to the fuel filter as “this invention” or “the present invention” . . . . The public is entitled to take the patentee at his word and the word was that the invention is a fuel filter.

. . . .

Nevertheless, even if we were to agree with Honeywell that the patentee clearly expressed his intention during prosecution to have the “fuel injection system component” limitation include components in addition to a fuel filter, it would not change the result in this case. As we determined above, the written description provides only a fuel filter that is made with polymer housing and electrically conductive fibers interlaced therein. No other fuel injection system component with the claimed limitations is disclosed or suggested. Where, as here, the written description clearly identifies what his invention is, an expression by a patentee during prosecution that he intends his claims to cover more than what his specification discloses is entitled to little weight.<sup>194</sup>

A lesson here is that a description not consistent with the claims by being more narrowly focused on an invention (fuel filter) cannot be expanded or corrected during prosecution!

The Claims, Description and Abstract sections were sufficient. The deficiency was in the introductory sections.<sup>195</sup> The introductory sections should have followed the broadest claim with the “fuel filter” described as one of many fuel system components. By copying the broadest claim into the introductory sections, the entire patent specification remains consistent and focused upon the new result. When the introductory sections are not consistent with the broadest claim by being either broader or narrower, that broad claim can be interpreted to be consistent with those introductory sections.

#### *E. Separating the New from the Old—Multiform v. Medzam*

U.S. Patent No. 4,853,266 discloses and claims an envelope or bag which is degradable in liquid.<sup>196</sup> The bag is placed between the wall of a shipping container

---

<sup>194</sup> *Honeywell*, 452 F.3d at 1318–19 (citations omitted) (citing *Biogen, Inc. v. Berlex Labs.*, 318 F.3d 1132, 1140 (Fed. Cir. 2003) (stating that “[r]epresentations during prosecution cannot enlarge the content of the specification”)).

<sup>195</sup> See U.S. Patent No. 5,164,879 col. 1 ll.8–49.

<sup>196</sup> U.S. Patent No. 4,853,266 (filed Mar. 1, 1988).

and the wall of a frangible container containing liquid so that the bag will degrade when exposed to liquid leaking from the frangible container.<sup>197</sup> Upon degrading in response to the liquid, the material within the bag will absorb and immobilize the spilled liquid.<sup>198</sup>

The accused device utilizes a porous bag, like a tea bag, which bursts open in response to expansion of the contents including material for absorbing and immobilizing the spilled liquid.<sup>199</sup>

The district court in *Multiform Dessicants, Inc. v. Medzam, Ltd.*<sup>200</sup> held that “degradable” does not cover a bag that bursts because “degradable” as used in the ’266 patent means “that the envelope at least partially dissolves and thereby disintegrates in the liquid.”<sup>201</sup> The CAFC affirmed that “the specification and prosecution history do not support a meaning of ‘degradable’ that would include an envelope that bursts open from inner pressure without any dissolution.”<sup>202</sup> “The district court defined ‘degradable’ in light of the mode of action of the accused device, a pragmatic expedient relevant to the issue in litigation.”<sup>203</sup>

In the Background section of the ’266 patent, the prior art is described as including a “degradable” envelope containing a liquid absorbing and immobilizing material.<sup>204</sup> The Summary section makes it clear that the new result was to add a second material in the “degradable” envelope “for treating said liquid to nullify a specific undesirable quality thereof.”<sup>205</sup> Correspondingly, the claims were limited to include this second material.<sup>206</sup> Thus, the new result resided in the second material and did not rely upon the “degradable” envelope.

Clearly, the patent specification states that the envelope used in the new result is “degradable.”<sup>207</sup> Consequently, this patent was interpreted to include a specific species, i.e., a “degradable” bag, which was per se known in the prior art, for delivering the novel second material.<sup>208</sup> In other words, any generic envelope could be used to deliver the second material.

This patent might have been saved had the steps been followed to draft a picture claim, separate old from new, and prune and distill the picture claim into the broadest expression of the new result by simply making sure each word is necessary in the claim. For example, claim 1 needed to be pruned and distilled as follows:

1. *A packet for absorbing and immobilizing a liquid comprising:*

~~*an envelope which is degradable in said liquid,*~~

---

<sup>197</sup> *Id.* at col. 5 ll.4–26.

<sup>198</sup> *Id.* at col.5 ll.26–29.

<sup>199</sup> *Multiform Dessicants, Inc. v. Medzam, Ltd.*, No. 91-0095E, 1995 WL 737929, at \*5 (W.D.N.Y. Dec. 7, 1995), *aff’d*, 133 F.3d 1473 (Fed. Cir. 1998).

<sup>200</sup> *Id.*

<sup>201</sup> *Id.* at \*11.

<sup>202</sup> *Multiform Dessicants, Inc. v. Medzam, Ltd.*, 133 F.3d 1473, 1478 (Fed. Cir. 1998).

<sup>203</sup> *Id.*

<sup>204</sup> U.S. Patent No. 4,853,266 col. 1 ll.19–28 (filed Mar. 1, 1988).

<sup>205</sup> *Id.* at col. 1 ll.46–52.

<sup>206</sup> *Multiform*, 133 F.3d at 1478.

<sup>207</sup> U.S. Patent No. 4,853,266 col. 6 l.18–col. 8 l.23.

<sup>208</sup> *Multiform*, 133 F.3d at 1478.

*a first material ~~in said envelope~~ for absorbing and immobilizing said liquid,*

*an envelope confining said first material and constructed to release said material in response to the presence of said liquid.*

*and characterized by*

*a second material confined in said envelope for additionally treating said liquid which is absorbed and immobilized to nullify a specific undesirable quality thereof.*

By separating the new result of the second material from the old, “degradable” envelope, the patent drafter should have been guided toward any envelope which would deliver the second material. The separation requires the drafter to recite the prior art in the broadest possible expression and only to the specificity necessary to support the delivery of the second material. The entire application would have been focused around adding the second material with the envelope being capable of losing its confining force in the presence of the liquid. Dissolution/degradation would have then been presented as but one species of the envelope.

The fundamental error in the preparation of this application was the inclusion of a specific prior art “degradable” envelope in the broadest expression of the invention. This error was repeated throughout the various sections of the application.

However, this error was recognized during the pendency of the application before the PTO and more generic patent claims 11–18 were added.<sup>209</sup> Instead of “degradable” these claims recited a “means for containing said first and second materials while said means are dry and for releasing said first and second materials on contact of said means with said liquid.”<sup>210</sup> Nevertheless, the CAFC concluded that the meaning of “degradable . . . [was] limited to the dissolution/degradation of the envelope as described in the specification” and gave no credit to Multiform’s broader dictionary definitions added during patent prosecution.<sup>211</sup>

By focusing on the new result, the patent drafter is guided toward the broadest possible expression of the prior art in which the new result finds utility. The entire application would have been focused around adding the second material with the envelope being capable of losing its confining force in the presence of the liquid. The dissolution or degradation would have then been presented as but one species of the envelope along with other examples of an envelope to release contents upon contacting the liquid.

---

<sup>209</sup> *Multiform*, 1995 WL 737929, at \*5.

<sup>210</sup> *Id.* at \*4.

<sup>211</sup> *Multiform*, 133 F.3d at 1478.

*F. Successfully Incorporating the Preparation Steps—Teleflex v. Ficosa*

At issue in *Teleflex v. Ficosa*,<sup>212</sup> was U.S. Patent No. 5,632,182 directed to a “Serviceable Clip Core Coupling,” which is a component of a two-piece shift cable installed by General Motors (“GM”) in certain sport utility vehicles.<sup>213</sup> The two-piece shift cable connects the shift knob with the automatic transmission of the sport utility vehicle so that when a driver moves the shift knob, e.g., from “Park” to “Drive,” the transmission is engaged.<sup>214</sup> The two-piece cable allows GM to wait until an advanced stage of the manufacturing process before putting the two cable pieces together and permits the cable to be taken apart later for servicing.<sup>215</sup>

The Detailed Description repeats the claim language and becomes more specific and picture-like in detail as to the configuration of the clip by reference to FIG. 4.<sup>216</sup>

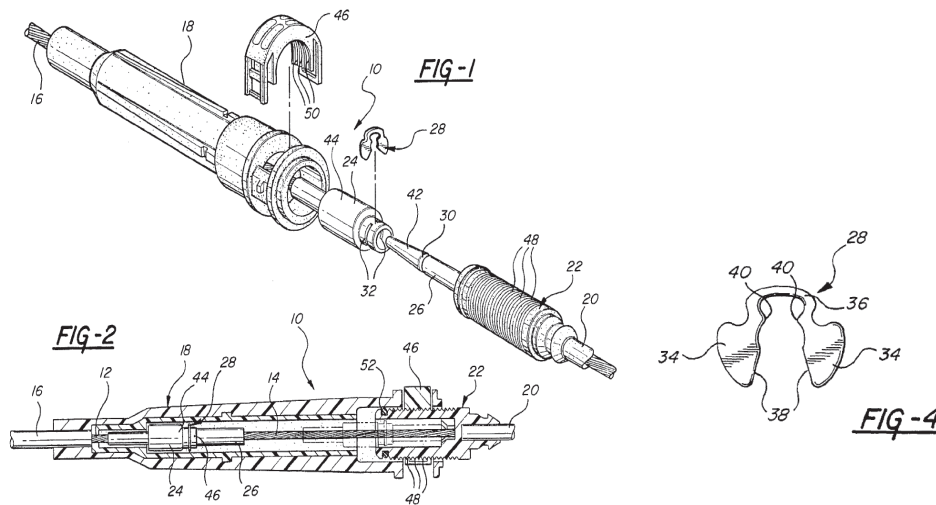

[T]he clip 28 is generally U-shaped with the legs 34 of the U-shape being flexible for flexing apart during disposition about the female member 24 and snapping into the slots 32 and the male groove 30. As will be appreciated, the legs are allowed to move apart or flex and return to their steady state condition because the base 36 of the U-shape which interconnects the legs 34 acts like a spring, i.e., like a leaf spring. The pair of the slots 32 are diametrically opposed in the female member 24 with each of the slots 32 receiving one leg 34 of the clip 28 when in the locked position. To facilitate insertion of the clip 28 into the slots 32, each leg 34 of the clip 28 includes a curved or arcuate cam edge 38 for engaging the ends of the

<sup>212</sup> *Teleflex, Inc. v. Ficosa N. Am. Corp.*, 299 F.3d 1313 (Fed. Cir. 2002).

<sup>213</sup> *Id.* at 1318; U.S. Patent No. 5,632,182 (filed Nov. 21, 1995).

<sup>214</sup> *Ficosa*, 299 F.3d at 1318.

<sup>215</sup> *Id.*

<sup>216</sup> U.S. Patent No. 5,632,182 col.2 ll.48–62.

slots 32 to force the legs 34 to flex or move apart by bending the base 36 during insertion.<sup>217</sup>

Ficosa argued and the district court agreed that the “clip” should be interpreted to include a “single pair of legs” as in the embodiment described in the patent.<sup>218</sup> However, the CAFC reversed and opined:

The patentee may demonstrate an intent to deviate from the ordinary and accustomed meaning of a claim term by including in the specification expressions of manifest exclusion or restriction, representing a clear disavowal of claim scope.

... We hold that claim terms take on their ordinary and accustomed meanings unless the patentee demonstrated an intent to deviate from the ordinary and accustomed meaning of a claim term by redefining the term or by characterizing the invention in the intrinsic record using words or expressions of manifest exclusion or restriction, representing a clear disavowal of claim scope.

In this case, nothing in the intrinsic evidence indicates that “clip (28)” should be limited to “a single pair of legs.” The language of asserted claim 1 does not support limiting the claim to a “single pair of legs.” Neither “single” nor “pair of legs” appears in claim 1. Neither the specification nor the prosecution history includes an expression of manifest exclusion or restriction demonstrating an intent to limit “clip (28)” to a single pair of legs. The term “clip” is not defined in the specification or in the prosecution history, and although the specification describes only one embodiment of the clip, no “clear statements of scope” limit the term “clip” to having a “single pair of legs.” Furthermore, the ordinary meaning of “clip” is not restricted to having a “single pair of legs.” The expert witnesses for Ficosa agreed that the ordinary meaning of “clip” is broad enough to encompass the accused Ficosa device in this case.

... The specification describes only one embodiment of the claimed “clip (28),” but in the circumstances of this case the record is devoid of “clear statements of scope” limiting the term appearing in claim 1 to having “a single pair of legs.” Absent such clear statements of scope, we are constrained to follow the language of the claims, rather than that of the written description.<sup>219</sup>

This patent does not include a picture claim, but it did basically copy all of the claims of descending scope into the Description for editing. The Technical Field is patterned after the preamble. The Background section referred to a prior art patent, U.S. 5,039,138, which disclosed two core elements irreversibly snapped together in

---

<sup>217</sup> *Id.*

<sup>218</sup> *Ficosa*, 299 F.3d at 1319.

<sup>219</sup> *Id.* at 1325–28 (citations omitted).



such an assembly.<sup>220</sup> The Background section included, “However, it frequently occurs that later in the life of the automobile there is also a need to take the two conduit and core sections apart for service to the automobile.”<sup>221</sup> The Summary includes all of claim 1 including the “characterized by” clause as filed.<sup>222</sup> However, the Summary should have been amended commensurate with the limitations added to the broadest claim during prosecution of the application before the PTO.

The critical lesson of this case is that the court could find nothing in the patent or file history whereby “the patentee demonstrated an intent to deviate from the ordinary and accustomed meaning of a claim term by redefining the term or by characterizing the invention in the intrinsic record using words or expressions of manifest exclusion or restriction, representing a clear disavowal of claim scope.”<sup>223</sup>

This patent followed the recognition and presentation steps and survived.

## IX. SUMMARY

Cole alerts us that evidence of a new result is necessary in the patent application in the EPC.<sup>224</sup> The opinions of U.S. case law also evidence a need for such a new result to support patentability. A safe harbor where a patent has the best chance of survival in a litigation storm is established by dividing the preparation of a patent application into two separate categories, i.e., recognition and presentation. The presentation category is satisfied by applying specific steps in drafting and correlating the various sections of the patent application.

In addition to identifying the new result or function to justify the exclusive right of a patent, a safe harbor of enforceability is not reached until that new result is systematically recited throughout all sections of a patent application. Because a court may interpret a patent based upon the intrinsic patent alone, without regard to extrinsic evidence presented in advocacy outside the patent document, extreme care should be exercised in preparing the original patent application with consistency throughout. It is important to realize that patent offices, for the most part, grant patents based upon claims whereas the courts enforce patents based upon the entire patent.

The problem with many decisions diminishing patent rights resides not in the application of the law or courts but in the initial preparation of patent applications. As Judge Linn stated, “[T]hese intriguing problems . . . are sort of self-inflicted by practitioners.”<sup>225</sup> To paraphrase Commodore Oliver Perry and Pogo: “We have seen the enemy and they are us!”<sup>226</sup>

---

<sup>220</sup> U.S. Patent No. 5,632,182 col.1 ll.30–35; see U.S. Patent No. 5,039,138 (filed Feb. 26, 1990).

<sup>221</sup> U.S. Patent No. 5,632,182 col. 1 ll. 32–35.

<sup>222</sup> *Id.* at col. 1 ll.39–51, col. 3 l.45–col. 4 l.9.

<sup>223</sup> *Ficosa*, 299 F.3d at 1325, 1328.

<sup>224</sup> See COLE, *supra* note 4.

<sup>225</sup> Recording of oral argument, *Logan v. Hormel Foods, Inc.*, 217 F. App’x 942 (Fed. Cir. 2007), available at <http://www.ca9.uscourts.gov/oral-argument-recordings/2006-1114/all>.

<sup>226</sup> Accord WALT KELLY, POGO: WE HAVE MET THE ENEMY AND HE IS US (1972) (parodying Oliver Hazard Perry’s letter to General William Henry Harrison, which stated, “We have met the enemy and they are ours”).